



sarens
group

www.sarens.com

LIEBHERR LTM 1060/2

60 TON

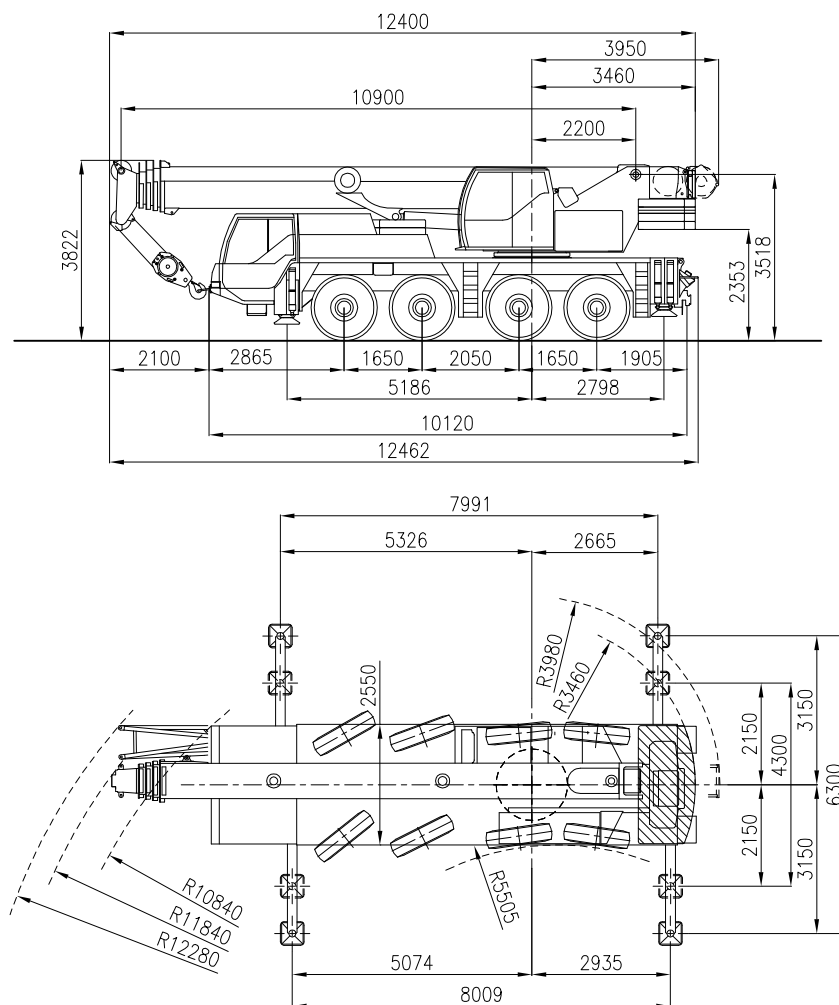

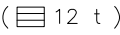
Axle load / Charge par essieu / Achslast / Aslast	: 4 x 12 t	()
Total weight / Poids total / Gesamtgewicht / Totaal gewicht	: 48 t	()
Tyres / Pneus / Bereifung / Banden	: 14.00 R 25	

nothing too heavy, nothing too high





LIEBHERR LTM 1060/2

Working ranges
Portées

60 TON

Arbeitsbereiche
Werkbereich

T

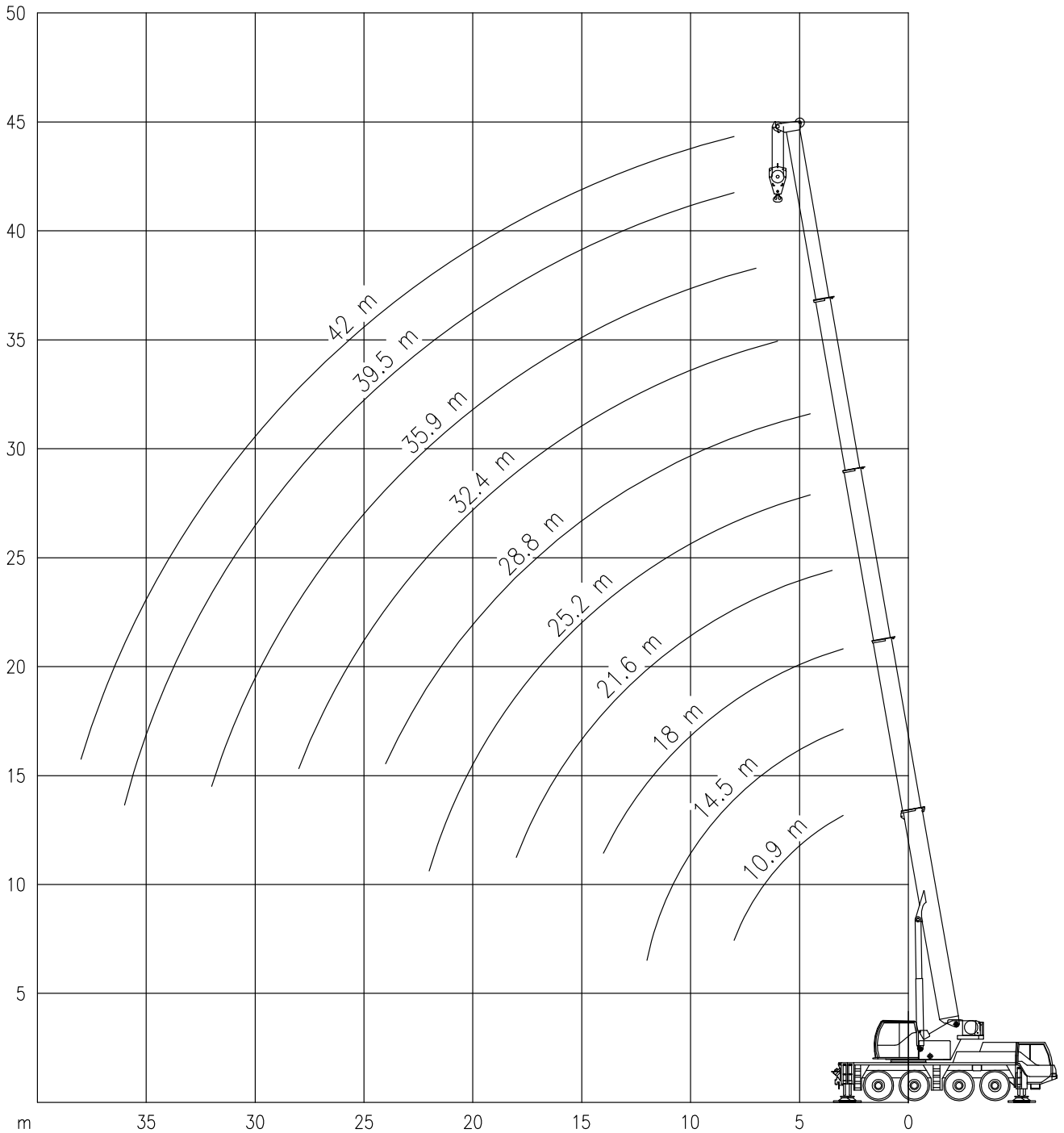



LIEBHERR LTM 1060/2

60 TON

Capacities
Capacités

Tragfähigkeiten
Capaciteiten

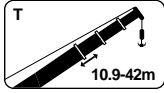

T

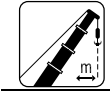
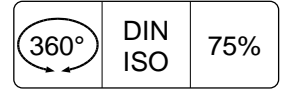
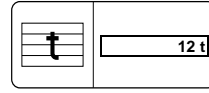

	10.9 m	14.5 m	18.0 m	21.6 m	25.2 m	28.8 m	32.4 m	35.9 m	39.5 m	42.0 m
m	t	t	t	t	t	t	t	t	t	t
3.0	51.0*	51.0*	45.0*	-	-	-	-	-	-	-
3.5	46.5*	46.0*	42.0	37.5	-	-	-	-	-	-
4.0	42.5	42.0	39.0	35.0	-	-	-	-	-	-
4.5	38.5	38.5	36.5	33.0	27.8	24.5	-	-	-	-
5.0	35.5	35.0	34.0	31.0	28.1	25.0	-	-	-	-
6.0	30.0	29.8	29.4	27.2	25.1	22.5	19.8	-	-	-
7.0	25.7	25.2	24.8	24.2	22.5	20.3	18.3	15.3	-	-
8.0	21.9	21.7	21.0	20.2	19.7	18.5	17.0	14.3	11.8	10.1
9.0	-	18.9	18.9	17.1	16.8	16.1	15.6	13.4	11.1	9.5
10.0	-	16.1	16.2	14.7	14.5	14.0	13.9	12.6	10.5	9.1
12.0	-	12.3	12.3	11.4	12.1	10.8	10.9	10.7	9.4	8.2
14.0	-	-	9.6	10.2	9.5	9.2	8.8	8.7	8.5	7.5
16.0	-	-	-	8.2	7.6	8.1	7.1	7.6	7.2	6.9
18.0	-	-	-	6.8	6.6	6.8	6.2	6.4	6.1	6.0
20.0	-	-	-	-	5.8	5.8	5.4	5.2	4.9	4.9
22.0	-	-	-	-	4.9	4.8	4.6	4.4	4.1	4.1
24.0	-	-	-	-	-	4.2	4.0	3.8	3.5	3.5
26.0	-	-	-	-	-	-	3.5	3.3	3.0	3.0
28.0	-	-	-	-	-	-	3.1	2.9	2.6	2.6
30.0	-	-	-	-	-	-	-	2.5	2.2	2.2
32.0	-	-	-	-	-	-	-	2.2	1.9	1.9
34.0	-	-	-	-	-	-	-	-	1.6	1.6
36.0	-	-	-	-	-	-	-	-	1.3	1.4
38.0	-	-	-	-	-	-	-	-	-	1.1

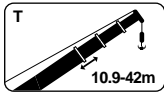

T

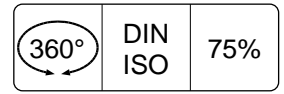
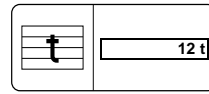

	10.9 m	14.5 m	18.0 m	21.6 m	25.2 m	28.8 m	32.4 m	35.9 m	39.5 m	42.0 m
m	t	t	t	t	t	t	t	t	t	t
3.0	43.5	43.5	43.0	-	-	-	-	-	-	-
3.5	39.5	39.0	38.5	36.0	-	-	-	-	-	-
4.0	35.5	35.0	33.5	31.0	-	-	-	-	-	-
4.5	32.5	32.0	28.8	26.6	25.2	23.5	-	-	-	-
5.0	29.7	28.3	27.2	23.3	22.3	20.9	-	-	-	-
6.0	24.2	23.1	21.6	18.8	19.0	17.4	16.5	-	-	-
7.0	18.7	18.8	17.8	17.1	15.9	15.3	13.9	13.6	-	-
8.0	14.9	15.6	14.9	14.5	13.5	13.6	12.4	12.2	11.3	10.1
9.0	-	12.9	12.8	12.9	12.1	11.8	11.2	10.6	9.9	9.5
10.0	-	10.9	11.3	11.3	10.8	10.4	9.9	9.3	8.7	8.6
12.0	-	8.1	8.4	8.7	8.5	8.3	7.8	7.4	6.9	6.8
14.0	-	-	6.6	6.9	6.8	6.7	6.4	6.0	5.5	5.5
16.0	-	-	-	5.5	5.3	5.3	5.1	4.9	4.5	4.5
18.0	-	-	-	4.6	4.4	4.3	4.2	4.0	3.6	3.6
20.0	-	-	-	-	3.7	3.6	3.5	3.3	2.9	2.9
22.0	-	-	-	-	3.2	3.1	2.9	2.7	2.4	2.4
24.0	-	-	-	-	-	2.6	2.4	2.3	1.9	1.9
26.0	-	-	-	-	-	-	2.1	1.9	1.6	1.6
28.0	-	-	-	-	-	-	1.7	1.6	1.3	1.3
30.0	-	-	-	-	-	-	-	1.3	1.0	1.0
32.0	-	-	-	-	-	-	-	1.0	0.8	0.8

*Only with heavy duty attachment / Seulement avec dispositif pour charges lourdes / Nur mit schwerlasteinrichtung / Alleen met zware-last uitrusting.



LIEBHERR LTM 1060/2

Working ranges
Portées

60 TON

Arbeitsbereiche
Werkbereich

TK

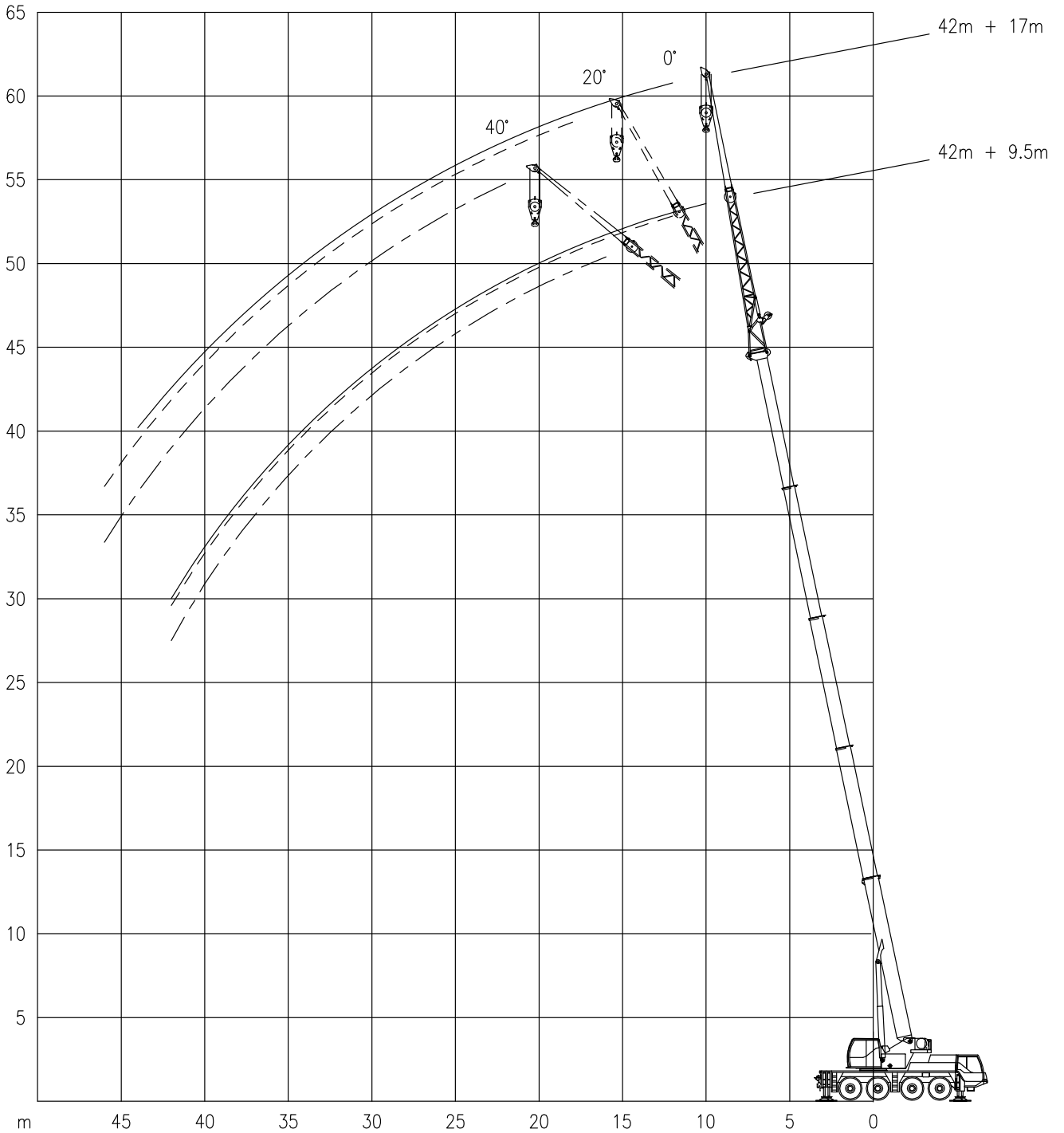



LIEBHERR LTM 1060/2

60 TON

Capacities
Capacités

Tragfähigkeiten
Capaciteiten

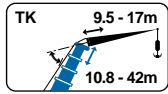

TK



6.3m

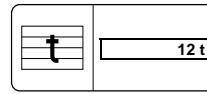

12 t

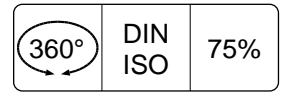

360°

DIN
ISO

75%

Main boom Flèche princ. Hauptausleger Hoofdgiek		9.5 m			17.0 m		
		0°	20°	40°	0°	20°	40°
		m	t	t	t	t	t
10.8 m	3.0	11.4	-	-	-	-	-
	3.5	11.4	-	-	-	-	-
	4.0	11.4	-	-	5.7	-	-
	4.5	11.4	-	-	5.7	-	-
	5.0	11.4	-	-	5.7	-	-
	6.0	11.4	9.2	-	5.7	-	-
	7.0	11.4	8.6	-	5.5	-	-
	8.0	10.7	8.0	6.5	5.2	-	-
	9.0	9.9	7.6	6.2	4.9	-	-
	10.0	9.2	7.3	5.9	4.6	3.7	-
	12.0	8.0	6.6	5.5	4.1	3.4	-
	14.0	7.0	6.1	5.2	3.7	3.1	2.7
	16.0	6.1	5.6	5.0	3.3	2.9	2.5
	18.0	-	-	-	3.1	2.7	2.4
	20.0	-	-	-	2.8	2.5	2.3
22.0	-	-	-	2.6	2.4	2.3	
24.0	-	-	-	2.4	2.3	-	
32.4 m	8.0	11.4	-	-	-	-	-
	9.0	10.8	-	-	4.6	-	-
	10.0	10.2	8.2	-	4.5	-	-
	12.0	9.2	7.7	-	4.3	-	-
	14.0	8.3	7.4	6.3	4.1	-	-
	16.0	6.9	7.1	6.1	3.9	3.1	-
	18.0	5.8	6.2	5.9	3.7	3.0	-
	20.0	4.6	4.9	5.1	3.5	2.9	2.4
	22.0	4.0	4.2	4.4	3.4	2.8	2.4
	24.0	3.6	3.7	3.8	3.2	2.7	2.3
	26.0	3.3	3.3	3.5	3.1	2.6	2.3
	28.0	3.0	3.1	3.2	2.7	2.5	2.3
	30.0	2.6	2.7	2.8	2.5	2.4	2.2
	32.0	2.3	2.4	2.4	2.3	2.4	2.2
	34.0	2.0	2.1	2.1	2.1	2.2	2.2
36.0	1.7	1.8	1.8	1.9	2.1	2.2	
38.0	1.4	1.5	-	1.7	1.8	1.9	
40.0	-	-	-	1.4	1.6	1.7	
42.0	-	-	-	1.2	1.4	1.4	
44.0	-	-	-	1.1	1.1	1.1	
46.0	-	-	-	0.9	0.9	-	
35.9 m	8.0	9.2	-	-	-	-	-
	9.0	9.0	-	-	-	-	-
	10.0	8.5	-	-	4.2	-	-
	12.0	7.7	7.4	-	4.0	-	-
	14.0	7.0	6.7	6.0	3.8	-	-
	16.0	6.3	6.0	5.8	3.7	3.1	-
	18.0	5.6	5.5	5.6	3.6	2.9	-
	20.0	4.6	4.9	5.1	3.4	2.8	2.4
	22.0	4.2	4.1	4.4	3.3	2.7	2.4
	24.0	3.7	3.8	3.9	3.2	2.6	2.3
	26.0	3.2	3.4	3.5	3.0	2.6	2.3
	28.0	2.8	2.9	3.0	2.8	2.5	2.2
	30.0	2.4	2.5	2.6	2.6	2.5	2.2
	32.0	2.1	2.2	2.3	2.2	2.4	2.2
	34.0	1.8	1.9	2.0	1.9	2.2	2.2
36.0	1.5	1.6	1.7	1.7	1.9	2.1	
38.0	1.3	1.4	1.4	1.5	1.6	1.8	
40.0	1.1	1.1	1.1	1.3	1.4	1.5	
42.0	0.9	0.9	-	1.1	1.2	1.3	
44.0	-	-	-	0.9	1.0	1.1	
46.0	-	-	-	0.7	0.8	0.8	
48.0	-	-	-	0.6	0.7	-	



LIEBHERR LTM 1060/2

60 TON

Capacities
Capacités

Tragfähigkeiten
Capaciteiten

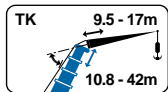

TK



6.3m

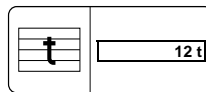

12 t

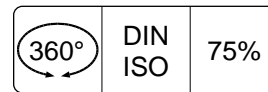

360°

DIN
ISO

75%

Main boom Flèche princ. Hauptausleger Hoofdgiek		9.5 m			17.0 m		
		0°	20°	40°	0°	20°	40°
		m	t	t	t	t	t
39.5 m	9.0	7.0	-	-	-	-	-
	10.0	6.9	-	-	-	-	-
	12.0	6.4	6.0	-	3.6	-	-
	14.0	5.9	5.6	-	3.5	-	-
	16.0	5.4	5.2	4.9	3.4	-	-
	18.0	4.9	4.9	4.7	3.3	2.8	-
	20.0	4.5	4.5	4.5	3.2	2.7	2.4
	22.0	3.9	4.1	4.3	3.1	2.7	2.3
	24.0	3.4	3.6	3.8	3.0	2.6	2.3
	26.0	2.9	3.1	3.2	2.9	2.5	2.2
	28.0	2.4	2.7	2.8	2.6	2.4	2.2
	30.0	2.1	2.3	2.4	2.3	2.4	2.2
	32.0	1.8	1.9	2.0	1.9	2.2	2.2
	34.0	1.5	1.6	1.7	1.6	1.9	2.2
	36.0	1.2	1.4	1.4	1.4	1.7	1.8
	38.0	1.0	1.1	1.2	1.2	1.4	1.6
	40.0	0.8	0.9	0.9	1.0	1.2	1.3
42.0	0.6	0.7	0.7	0.8	1.0	1.1	
44.0	-	-	-	0.6	0.8	0.9	
46.0	-	-	-	-	0.6	0.7	
42.0 m	10.0	6.0	-	-	-	-	-
	12.0	5.9	5.4	-	3.5	-	-
	14.0	5.4	5.1	-	3.3	-	-
	16.0	5.0	4.7	4.6	3.2	-	-
	18.0	4.6	4.4	4.4	3.1	2.8	-
	20.0	4.2	4.2	4.1	3.1	2.7	-
	22.0	3.9	3.8	3.9	3.0	2.6	2.3
	24.0	3.3	3.5	3.7	2.9	2.5	2.3
	26.0	2.8	3.0	3.2	2.7	2.5	2.2
	28.0	2.4	2.6	2.8	2.5	2.4	2.2
	30.0	2.0	2.2	2.3	2.2	2.4	2.2
	32.0	1.7	1.9	2.0	1.9	2.2	2.2
	34.0	1.4	1.6	1.7	1.6	1.9	2.1
	36.0	1.2	1.3	1.4	1.3	1.6	1.8
	38.0	1.0	1.1	1.1	1.1	1.4	1.5
	40.0	0.8	0.9	0.9	0.9	1.1	1.3
	42.0	0.6	0.7	0.7	0.7	0.9	1.1
44.0	-	-	-	0.6	0.8	0.9	
46.0	-	-	-	-	0.6	0.7	

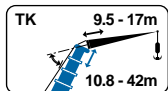

TK



6.3m

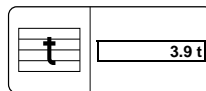

3.9 t

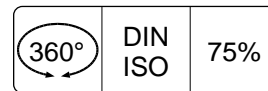

360°

DIN
ISO

75%

Main boom Flèche princ. Hauptausleger Hoofdgiek		9.5 m			17.0 m		
		0°	20°	40°	0°	20°	40°
		m	t	t	t	t	t
10.8 m	3.0	11.4	-	-	-	-	-
	3.5	11.4	-	-	-	-	-
	4.0	11.4	-	-	5.7	-	-
	4.5	11.4	-	-	5.7	-	-
	5.0	11.4	-	-	5.7	-	-
	6.0	11.4	9.2	-	5.7	-	-
	7.0	11.4	8.6	-	5.5	-	-
	8.0	10.7	8.0	6.5	5.2	-	-
	9.0	9.9	7.6	6.2	4.9	-	-
	10.0	9.2	7.3	5.9	4.6	3.7	-
	12.0	8.0	6.6	5.5	4.1	3.4	-
	14.0	7.0	6.1	5.2	3.7	3.1	2.7
	16.0	5.7	5.6	5.0	3.3	2.9	2.5
	18.0	-	-	-	2.8	2.7	2.4
	20.0	-	-	-	2.6	2.5	2.3
	22.0	-	-	-	2.4	2.4	2.3
	24.0	-	-	-	-	2.3	-



LIEBHERR LTM 1060/2

60 TON

Capacities
Capacités

Tragfähigkeiten
Capaciteiten

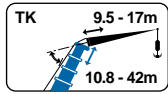

TK

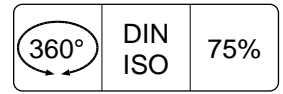
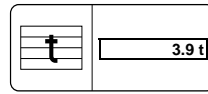

Main boom Flèche princ. Hauptausleger Hoofdgiek		9.5 m			17.0 m		
		0°	20°	40°	0°	20°	40°
		m	t	t	t	t	t
32.4 m	8.0	11.1	-	-	-	-	-
	9.0	9.5	-	-	4.6	-	-
	10.0	8.3	8.2	-	4.5	-	-
	12.0	6.8	7.0	-	4.3	-	-
	14.0	5.7	5.6	6.1	4.1	-	-
	16.0	4.6	5.1	4.9	3.9	3.1	-
	18.0	3.8	4.2	4.5	3.5	3.0	-
	20.0	3.2	3.5	3.7	3.3	2.9	2.4
	22.0	2.6	2.8	3.0	2.8	2.8	2.4
	24.0	2.1	2.3	2.5	2.3	2.6	2.3
	26.0	1.7	1.9	2.1	1.9	2.3	2.3
	28.0	1.4	1.6	1.7	1.6	1.9	2.2
	30.0	1.1	1.3	1.4	1.3	1.6	1.8
	32.0	0.9	1.0	1.1	1.1	1.3	1.5
	34.0	0.7	0.8	0.8	0.9	1.1	1.3
36.0	-	-	0.6	0.7	0.9	1.0	
38.0	-	-	-	-	0.7	0.8	
40.0	-	-	-	-	-	0.6	
35.9 m	8.0	9.2	-	-	-	-	-
	9.0	9.0	-	-	-	-	-
	10.0	8.0	-	-	4.2	-	-
	12.0	6.6	6.8	-	4.0	-	-
	14.0	5.3	5.6	5.9	3.8	-	-
	16.0	4.3	4.7	4.9	3.7	3.1	-
	18.0	3.5	3.9	4.2	3.4	2.9	-
	20.0	2.9	3.2	3.5	3.0	2.8	2.4
	22.0	2.3	2.6	2.8	2.5	2.7	2.4
	24.0	1.9	2.1	2.3	2.1	2.5	2.3
	26.0	1.5	1.7	1.9	1.7	2.1	2.3
	28.0	1.2	1.4	1.5	1.4	1.7	2.0
	30.0	0.9	1.1	1.2	1.1	1.4	1.7
	32.0	0.7	0.8	0.9	0.9	1.2	1.4
	34.0	-	-	0.7	0.7	0.9	1.1
36.0	-	-	-	-	0.7	0.9	
38.0	-	-	-	-	-	0.7	
39.5 m	9.0	7.0	-	-	-	-	-
	10.0	6.9	-	-	-	-	-
	12.0	6.1	6.0	-	3.6	-	-
	14.0	4.8	5.3	-	3.5	-	-
	16.0	3.8	4.3	4.6	3.4	-	-
	18.0	3.1	3.5	3.7	3.2	2.8	-
	20.0	2.4	2.8	3.0	2.6	2.7	2.4
	22.0	1.9	2.3	2.4	2.1	2.7	2.3
	24.0	1.5	1.8	2.0	1.7	2.2	2.3
	26.0	1.2	1.4	1.5	1.3	1.8	2.2
	28.0	0.8	1.1	1.2	1.0	1.5	1.8
	30.0	-	0.8	0.9	0.8	1.2	1.5
	32.0	-	-	-	-	0.9	1.2
	34.0	-	-	-	-	0.6	0.9
	36.0	-	-	-	-	-	0.6
42.0 m	10.0	6.0	-	-	-	-	-
	12.0	5.9	5.4	-	3.5	-	-
	14.0	4.7	5.1	-	3.3	-	-
	16.0	3.7	4.2	4.6	3.2	-	-
	18.0	3.0	3.4	3.7	3.1	2.8	-
	20.0	2.4	2.7	3.0	2.5	2.7	-
	22.0	1.9	2.2	2.4	2.0	2.6	2.3
	24.0	1.4	1.7	2.0	1.6	2.1	2.3
	26.0	1.1	1.3	1.5	1.3	1.7	2.2
	28.0	0.8	1.0	1.2	1.0	1.4	1.8
	30.0	-	0.7	0.9	0.7	1.1	1.4
	32.0	-	-	-	-	0.8	1.1
	34.0	-	-	-	-	-	0.8
	36.0	-	-	-	-	-	0.6



LIEBHERR LTM 1060/2

60 TON

Working speeds
Vitesses de travail

Arbeitsgeschwindigkeiten
Werksnelheden

Mechanisms Mécanismes Antriebe Aandrijvingen	Speeds Vitesses Geschwindigkeiten Snelheden	Rope diameter Diamètre du câble Seildurchmesser Kabeldiameter	Single line pull Effort sur brin simple Zulässiger Seilzug je strang Toegelaten trekkracht / part	Length of ropes Longueur des cables Länge der Seile Kabellengte
Main hoist Levage sur flèche Hubwerk 1 Hijlslier 1	0-130 m/min	17 mm	57 kN	200 m
Auxiliary hoist Levage sur fléchette Hubwerk 2 Hijlslier 2	0-130 m/min	17 mm	52 kN	210 m
Slewing gear Orientation Drehwerk Zwenkwerk	0 – 2 RPM			
Travel speed Vitesse sur route Fahrgeschwindigkeit Rijsnelheid	0-75 / 80 km/h			
Booming up Relever la flèche Aufwippen Optoppen	83° 52 sec			
Telescope Téléscoper Teleskopieren Telescoperen	10.9 – 42m 200 sec			

Hook Block / Crane hook Crochet mouflé / Crochet simple

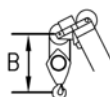

Unterflasche / Hakengehänge Kraanblok / Kraanhaak

Capacity Capacité Tragfähigkeit Capaciteit	Number of sheaves Nombre de poulies Anzahl der Rollen Aantal schijven	Number of lines Nombre de brins Strangzahl Aantal parten	Weight Poids Gewicht Gewicht	"B"
SWL 38.3 t	3	7	470 kg	3 m
SWL 16.9 t	1	3	352 kg	3 m