



sarens
group

www.sarens.com

KRUPP GMT-I

12 TON

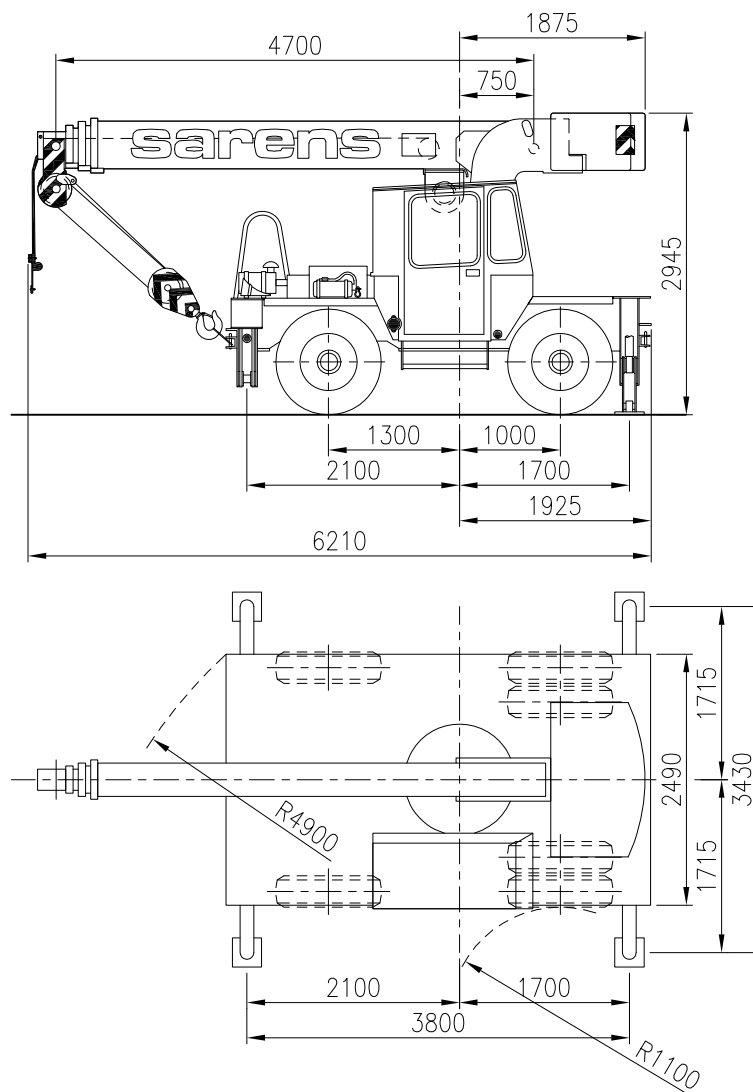

Front axle load / Charge essieu devant / Achslast / Aslast vooraan	:	7.8 t
Rear axle load / Charge essieu derrière / Achslast / Aslast achteraan	:	6.2 t
Total weight / Poids total / Gesamtgewicht / Totaal gewicht	:	14.0 t
Tyres / Pneus / Bereifung / Banden	:	10 x 20-16 PR

nothing too heavy, nothing too high





KRUPP GMT-I

Working ranges
Portées

12 TON

Arbeitsbereiche
Werkbereich

T

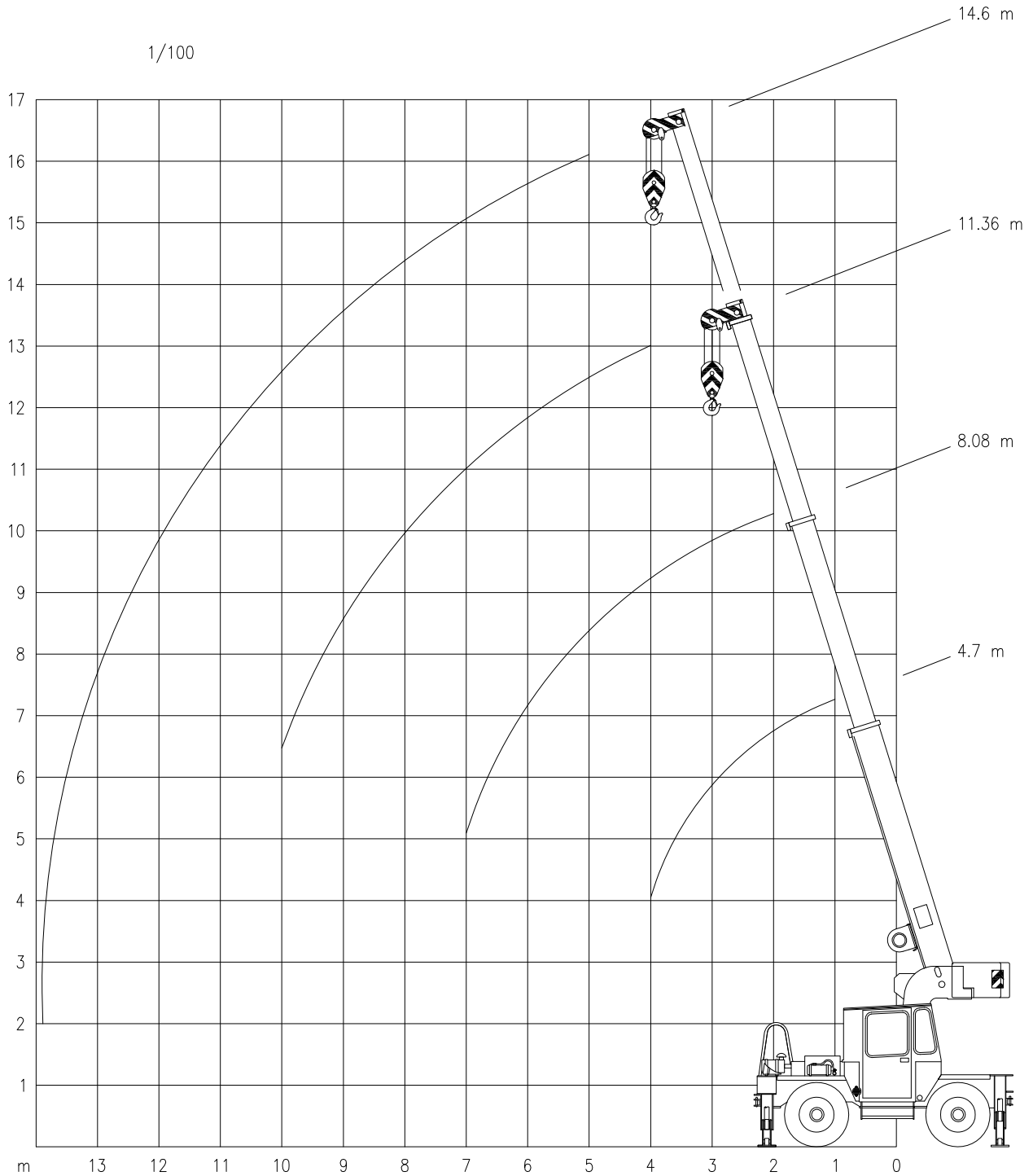



KRUPP GMT-I

Lifting capacities
Capacités

12 TON

Tragfähigkeiten
Capacités

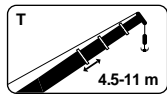

T

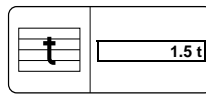

DIN
ISO

75%

m	A			B		
	Boom length 4.5 – 11 m variable / Longueur de fleche 4.5 – 11 m progressivement / Auslegerlänge 4.5 – 11 m Stufenlos / Gieklengthe 4.5 – 11 m traploos					
	360°	360° !*	0°	0° !*	360°	
t	t	t	t	t	t	t
1.0	12.0	12.0	10.2	11.5	8.9	
1.5	12.0	12.0	10.2	11.5	6.8	
2.0	12.0	12.0	7.2	10.0	5.4	
2.5	12.0	12.0	5.4	8.2	4.4	
3.0	10.8	10.8	4.4	6.8	3.6	
3.5	9.1	9.1	3.6	5.7	3.1	
4.0	7.5	7.7	3.0	5.0	2.6	
4.5	6.0	6.6	2.5	4.3	2.3	
5.0	4.9	5.9	2.2	3.8	2.0	
5.5	4.2	5.1	1.9	3.3	1.7	
6.0	3.7	4.6	1.7	2.9	1.5	
6.5	3.3	4.1	1.5	2.7	1.3	
7.0	2.9	3.7	1.3	2.4	1.1	
7.5	2.6	3.3	1.2	2.2	1.0	
8.0	2.3	3.0	1.0	2.0	0.9	
8.5	2.1	2.8	0.9	1.8	0.8	
9.0	1.9	2.5	0.8	1.6	0.7	
9.5	1.7	2.4	0.7	1.4	0.6	
10.0	1.5	2.2	0.6	1.3	0.5	

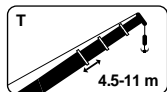

T

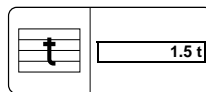

DIN
ISO

75%

m	4.70 m			8.08 m			11.36 m			14.60 m
	A	B	C	A	B	C	A	B	C	A
t	t	t	t	t	t	t	t	t	t	t
1.0	12.0	9.0	-	-	-	-	-	-	-	-
1.5	12.0	6.8	11.5	-	-	-	-	-	-	-
2.0	12.0	5.4	10.0	12.0	5.4	10.0	-	-	-	-
2.5	12.0	4.4	8.2	12.0	4.4	8.2	-	-	-	-
3.0	10.8	3.6	6.8	10.8	3.6	6.8	-	-	-	-
4.0	-	2.6	-	7.7	2.6	5.0	7.7	2.6	5.0	-
5.0	-	-	-	5.9	2.0	3.8	5.9	2.0	3.8	5.9
6.0	-	-	-	4.6	1.5	2.9	4.6	1.5	2.9	4.6
7.0	-	-	-	3.7	1.1	2.2	3.7	1.1	2.2	3.7
8.0	-	-	-	-	-	-	3.0	0.9	1.7	3.0
9.0	-	-	-	-	-	-	2.5	0.7	1.3	2.5
10.0	-	-	-	-	-	-	2.2	0.5	1.1	2.2
11.0	-	-	-	-	-	-	-	-	-	1.8
12.0	-	-	-	-	-	-	-	-	-	1.6
13.0	-	-	-	-	-	-	-	-	-	1.4
14.0	-	-	-	-	-	-	-	-	-	1.3

- !* = With 3.5t additional counterweight / Avec contrepoids supplementaire 3.5t / Mit 3.5t Zusatz-Gegengewicht / Met 3.5t extra tegengewicht
- A = On outriggers / Sur patins / Abgestützt / Afgestempeld
- B = On tyres / Sur pneus / Auf reifen / Op banden
- C = On tyres over front / Sur pneus en avant / Auf reifen nach vorne / Op banden over voorzijde.



KRUPP GMT-I

12 TON

**Working speeds
Vitesses de travail**

**Arbeitsgeschwindigkeiten
Werksnelheden**

Mechanisms Mécanismes Antriebe Aandrijvingen	Speeds Vitesses Geschwindigkeiten Snelheden	Rope diameter Diamètre du câble Seildurchmesser Kabeldiameter	Single line pull Effort sur brin simple Zulässiger Seilzug je strang Toegelaten trekkracht / part	Length of ropes Longueur des cables Länge der Seile Kabellänge
Main hoist Levage sur flèche Hubwerk 1 Hijlslier 1	0 - 60 m/min	13 mm	34 kN	60 m
Slewing gear Orientation Drehwerk Zwenkwerk	0 - 2 RPM			
Travel speed Vitesse sur route Fahrgeschwindigkeit Rijsnelheid	1.5 - 24 km/h			
Booming up Relever la flèche Aufwippen Optoppen	73° 16 / 36 sec			
Telescope Téléscoper Teleskopieren Telescoperen	4.5 - 11m 57 / 100 sec			

**Hook block/Crane hook
Crochet-mouflé/Crochet simple**

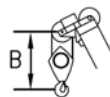

**Unterflasche/Hakengehänge
Kraanblok/Kraanhaak**

Capacity / Capacité Tragfähigkeit / Capaciteit	Number of sheaves / Nombre de poulies Anzahl der Rollen / Aantal schijven	Number of lines / Nombre de brins Strangzahl / Aantal parten	Weight / Poids Gewicht / Gewicht	"B"
SWL 12 t	3	6	170 kg	1.6 m
SWL 3 t	-	1	80 kg	1.3 m