



sarens
group

www.sarens.com

HITACHI SCX 2000

200 TON

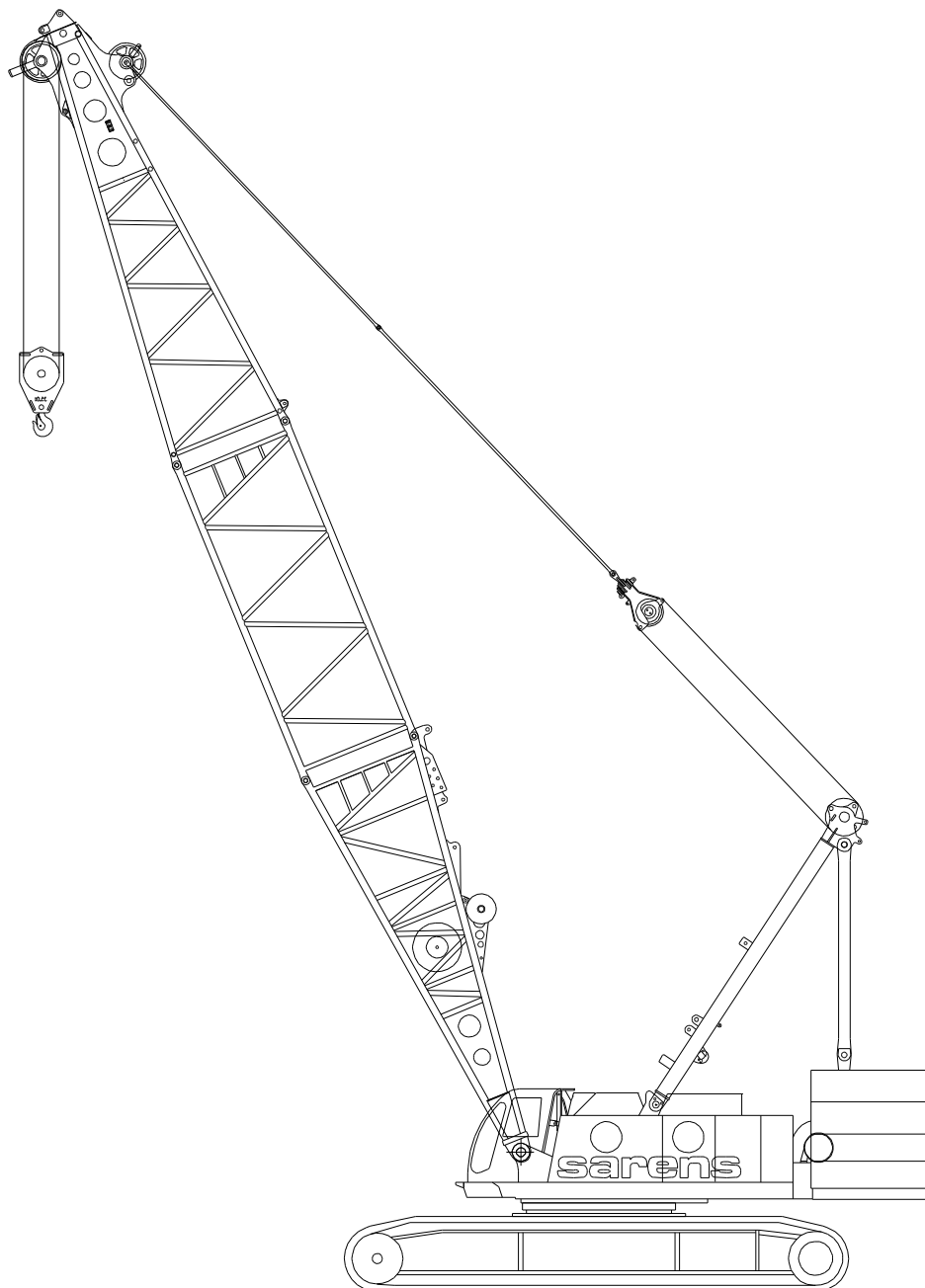

nothing too heavy, nothing too high





HITACHI SCX 2000

Dimensions
Dimensions

200 TON

Abmessungen
Afmetingen

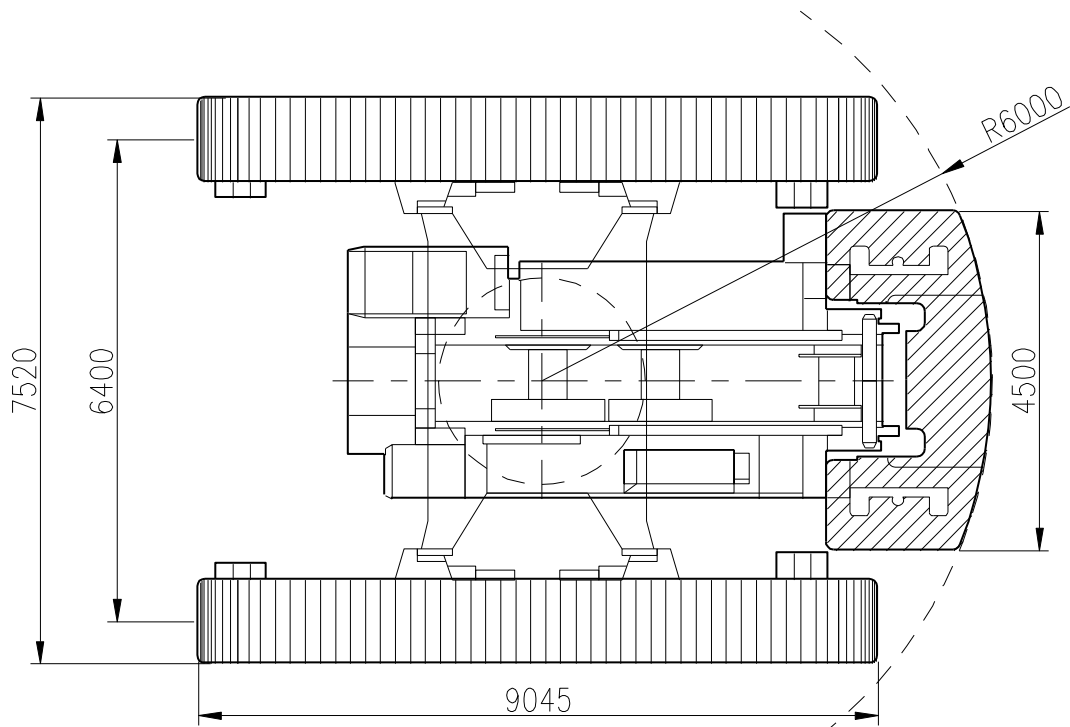
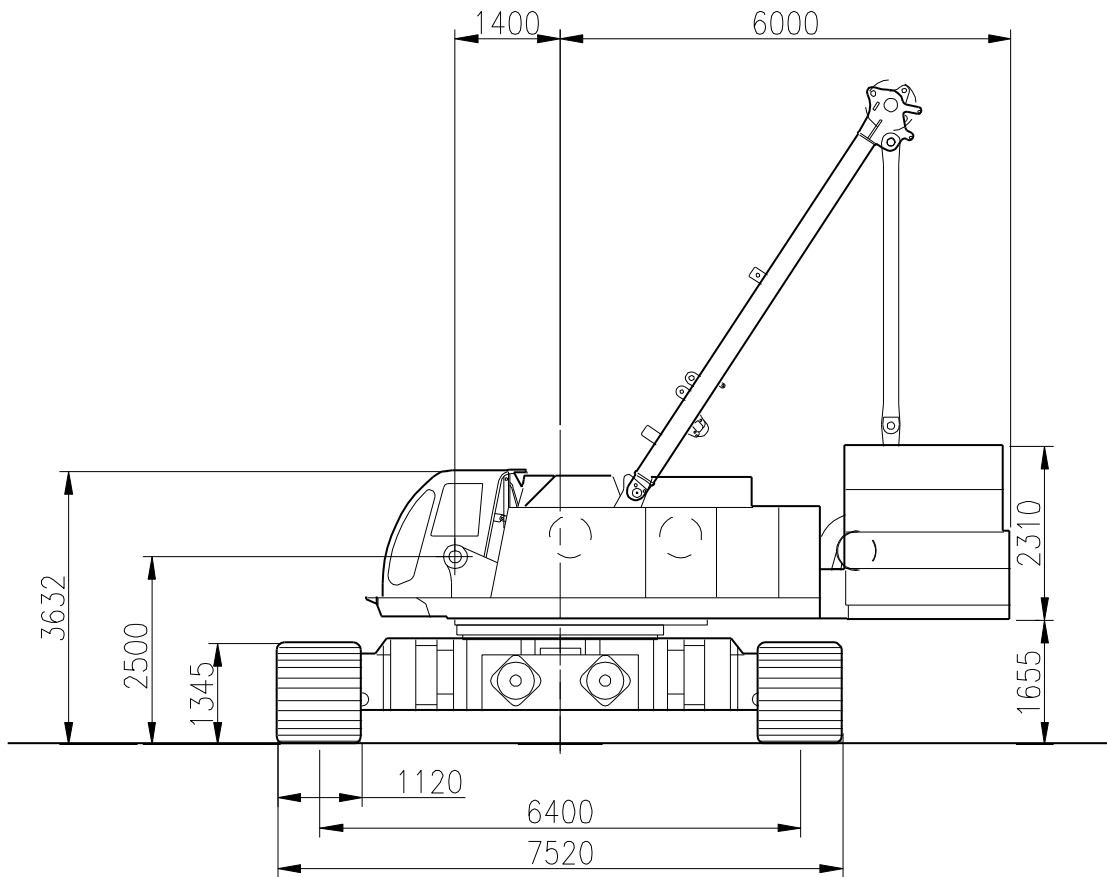



HITACHI SCX 2000

Dimensions Dimensions

200 TON

Abmessungen Afmetingen

Superstructure with carbody + winch I & II Partie supérieure avec carter central + treuil I & II Oberwagen mit Mittelstück Winde I & II Bovenwagen met centraal onderstelgedeelte I & II	56.3 t
Crawler unit Bâti de chenille Raupe Rups	2 x 21.1 t
Counterweight Contrepoids Gegengewicht Tegengewicht	86.3 t

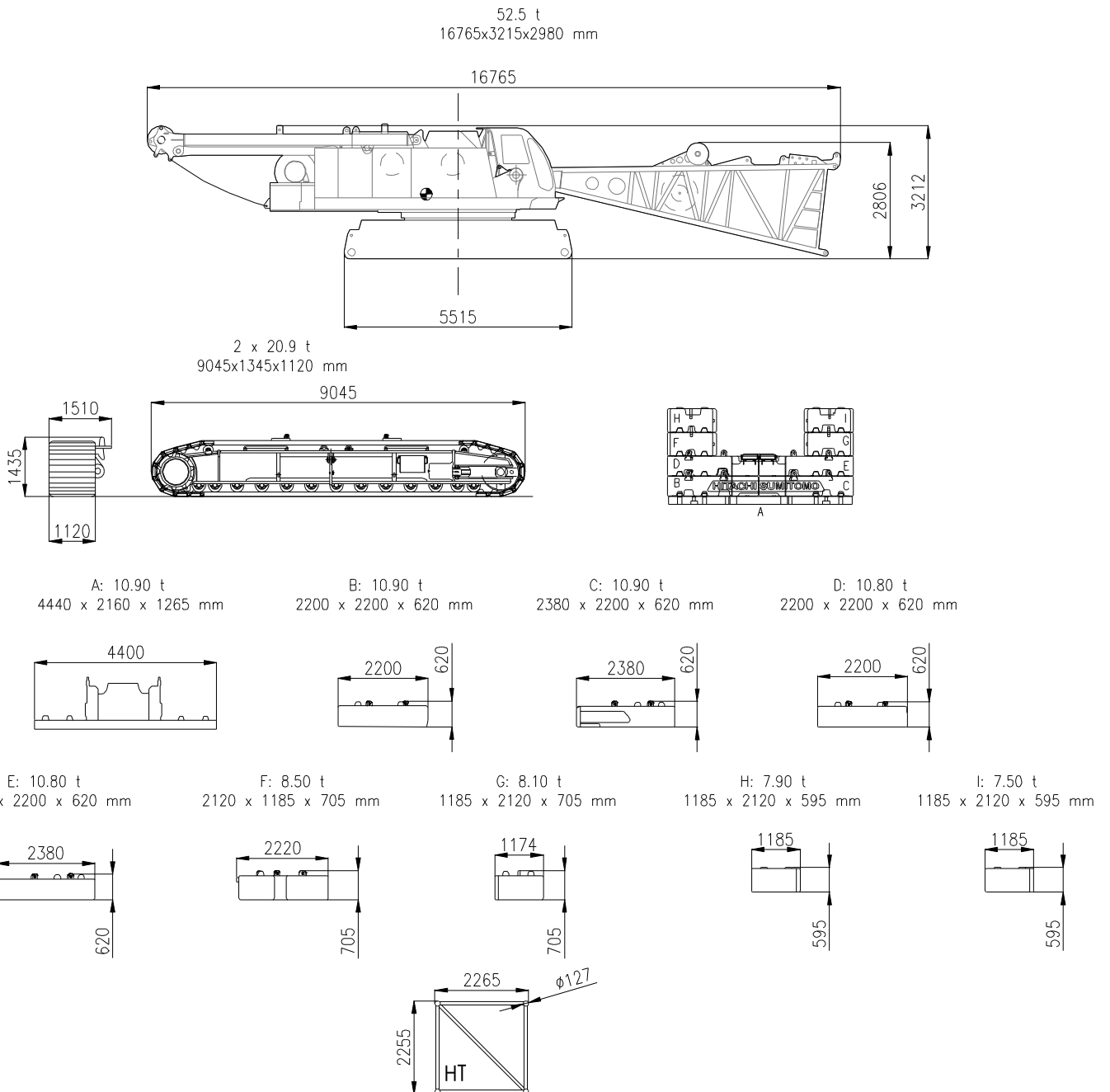



HITACHI SCX 2000

Working ranges
Portées

200 TON

Arbeitsbereiche
Werkbereich

HT

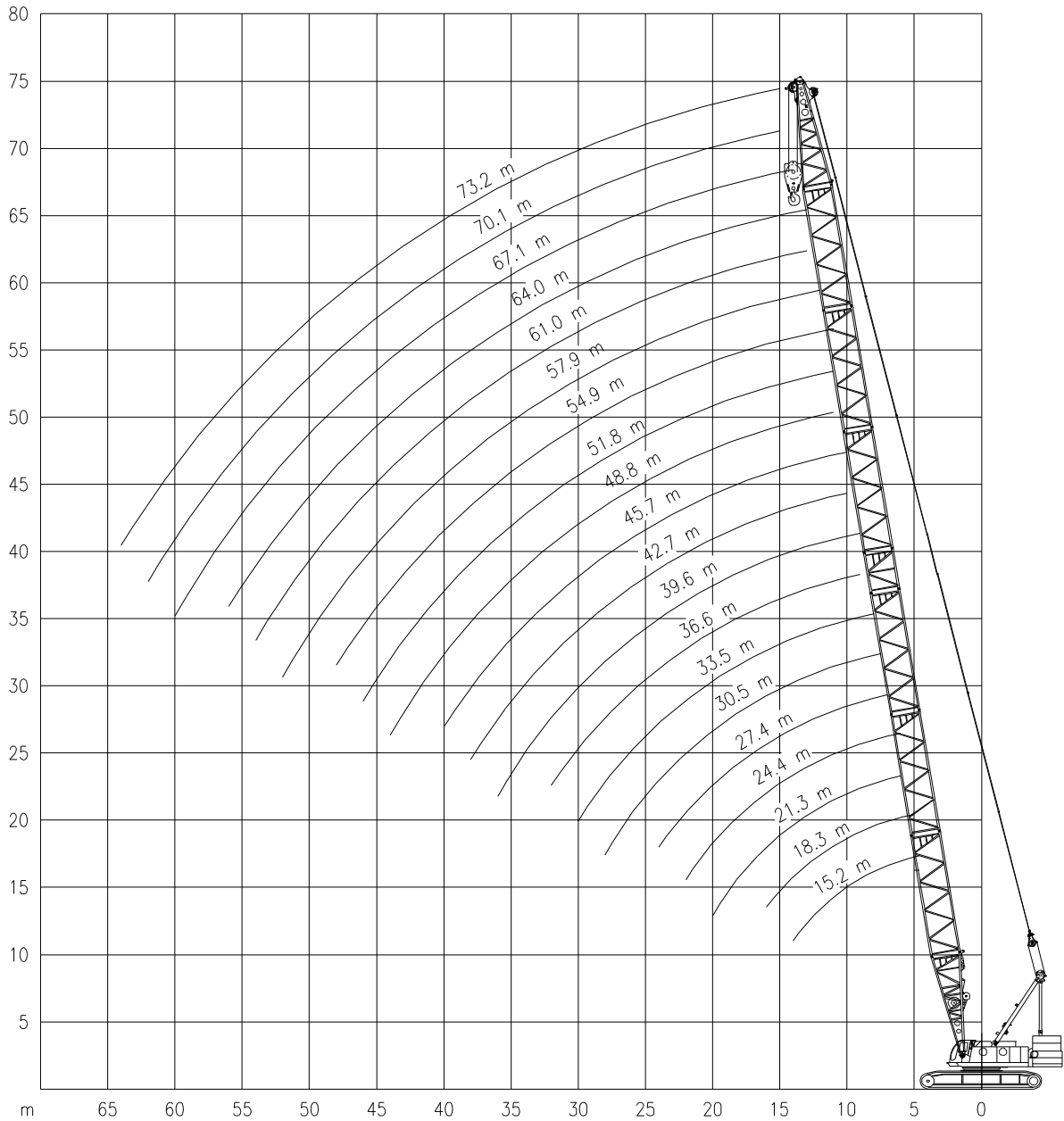



HITACHI SCX 2000

Lifting capacities
Capacités

200 TON

Tragfähigkeiten
Capaciteiten

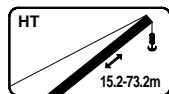

HT

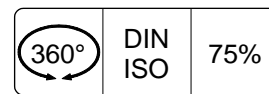
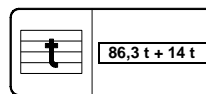

	15.2 m	18.3 m	21.3 m	24.4 m	27.4 m	30.5 m	33.5 m	36.6 m	39.6 m	42.7m
	t	t	t	t	t	t	t	t	t	t
4.6	200.0	(5.5m)	-	-	-	-	-	-	-	-
5.0	200.0	194.0	-	(6.5m)	-	-	-	-	-	-
6.0	192.0	191.0	189.0	175.0	-	(7.5m)	-	-	-	-
7.0	185.0	183.0	179.0	175.0	150.0	150.0	-	-	-	-
8.0	167.0	164.0	158.0	152.0	147.0	142.0	125.0	-	-	-
9.0	144.0	141.0	137.0	132.0	128.0	124.0	120.0	100.0	100.0	-
10.0	122.0	122.0	120.0	116.0	113.0	110.0	107.0	100.0	100.0	98.2
12.0	93.3	92.8	92.7	92.4	91.3	88.8	86.8	84.9	82.8	80.9
14.0	75.3	74.9	74.7	74.3	74.1	73.8	72.9	71.4	69.7	68.3
16.0	-	62.5	62.3	62.0	61.8	61.3	61.2	61.1	60.0	58.9
18.0	-	-	53.3	52.8	52.6	52.2	52.1	52.0	51.7	51.5
20.0	-	-	46.5	46.1	45.8	45.4	45.2	45.1	44.7	44.6
22.0	-	-	-	40.7	40.4	40.0	39.8	39.7	39.3	39.1
24.0	-	-	-	-	36.1	35.6	35.5	35.3	34.9	34.7
26.0	-	-	-	-	-	32.1	31.9	31.7	31.3	31.1
28.0	-	-	-	-	-	29.2	28.9	28.6	28.3	28.1
30.0	-	-	-	-	-	-	26.4	26.1	25.7	25.5
32.0	-	-	-	-	-	-	-	23.9	23.5	23.3
34.0	-	-	-	-	-	-	-	-	21.6	21.4
36.0	-	-	-	-	-	-	-	-	20.0	19.7
38.0	-	-	-	-	-	-	-	-	-	18.3

	45.7 m	48.8 m	51.8 m	54.9 m	57.9 m	61.0 m	64.0m	67.1 m	70.1 m	73.2m
	t	t	t	t	t	t	t	t	t	t
9.0	-	(11m)	(11m)	-	-	-	-	-	-	-
10.0	89.0	78.2	71.3	-	-	(13m)	(13m)	-	-	-
12.0	79.1	75.5	69.1	62.8	57.2	51.0	46.3	-	(15m)	(15m)
14.0	66.9	65.4	64.2	59.2	53.9	49.5	45.1	41.1	36.7	33.4
16.0	57.7	56.4	55.4	54.2	51.0	46.8	42.6	38.8	35.7	32.4
18.0	50.6	49.5	48.6	47.5	46.5	44.5	40.4	36.8	33.8	30.6
20.0	44.4	43.8	43.1	42.1	41.2	40.6	38.5	35.0	32.1	29.1
22.0	38.9	38.6	38.4	37.7	36.8	36.3	35.4	33.4	30.6	27.7
24.0	34.5	34.1	34.0	33.7	33.2	32.7	31.9	31.2	29.2	26.4
26.0	30.9	30.5	30.3	30.0	29.7	29.6	28.9	28.2	27.8	25.4
28.0	27.8	27.5	27.3	26.9	26.6	26.5	26.2	25.6	25.2	24.1
30.0	25.2	24.9	24.7	24.4	24.0	23.9	23.5	23.2	23.0	22.4
32.0	23.0	22.7	22.5	22.1	21.8	21.7	21.3	21.0	20.9	20.4
34.0	21.1	20.7	20.6	20.2	19.8	19.7	19.4	19.0	18.9	18.6
36.0	19.4	19.0	18.9	18.5	18.1	18.0	17.7	17.3	17.2	16.8
38.0	17.9	17.6	17.4	17.0	16.6	16.5	16.1	15.8	15.7	15.3
40.0	16.6	16.3	16.0	15.7	15.3	15.2	14.8	14.5	14.3	14.0
42.0	-	15.1	14.9	14.5	14.1	14.0	13.6	13.3	13.1	12.8
44.0	-	14.1	13.8	13.4	13.0	12.9	12.5	12.2	12.0	11.7
46.0	-	-	12.9	12.5	12.1	11.9	11.5	11.2	11.0	10.7
48.0	-	-	-	11.6	11.2	11.0	10.6	10.3	10.1	9.8
50.0	-	-	-	-	10.4	10.2	9.8	9.5	9.3	8.9
52.0	-	-	-	-	9.7	9.5	9.1	8.8	8.6	8.2
54.0	-	-	-	-	-	8.8	8.4	8.1	7.9	7.5
56.0	-	-	-	-	-	-	7.8	7.5	7.2	6.9
58.0	-	-	-	-	-	-	-	6.9	6.7	6.3
60.0	-	-	-	-	-	-	-	6.4	6.1	5.8
62.0	-	-	-	-	-	-	-	-	5.6	5.3
64.0	-	-	-	-	-	-	-	-	-	4.8

Values in brackets () represented below or above load capacity, indicate exact radius. / Les valeurs entre parenthèses () notées au-dessus ou en-dessous des capacités, indiquent les portées exactes (pour les dernières). / Die Werten in Klammern unten oder oben den Tragfähigkeiten bedeuten die genaue Ausladung. / Waarden tussen haakjes () onder of boven capaciteiten geven de exacte radius aan.



HITACHI SCX 2000

200 TON

Working speeds
Vitesses de travail

Arbeitsgeschwindigkeiten
Werksnelheden

Mechanisms Mécanismes Antriebe Aandrijvingen	Speeds Vitesses Geschwindigkeiten Snelheden	Rope diameter Diamètre du câble Seildurchmesser Kabeldiameter	Single line pull Effort sur brin simple Zulässiger Seilzug je strang Toegelaten trekkraft / part	Length of ropes Longueur des cables Länge der Seile Kabellänge
Main hoist Levage sur flèche Hubwerk 1 Hijslie 1	0 – 120 m/min	28 mm	245 kN	410 m
Auxiliary hoist Levage sur flèche Hubwerk 2 Hijslie 2	0 – 120 m/min	28 mm	245 kN	350 m
Hoist A-frame Relevage chevalet Einziehwerk Lier A-frame	2 x 0 – 24 m/min	22.4 mm	2 x 156 kN	310 m
Slewing gear Orientation Drehwerk Zwenkwerk	1 – 1.7 Rev./min			
Travel speed Vitesse sur route Fahrgeschwindigkeit Rijsnelheid	0 – 1.2 km/h			

Runner
Crochet rapide

Mastnase
Giekneus

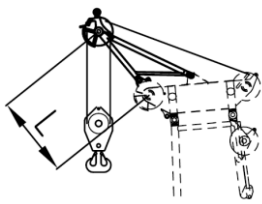
HH 	Capacity Capacité Tragfähigkeit Capaciteit	Max. 13.5t	L= 1535 mm
---	---	------------	------------

Hook Block / Crane hook
Crochet mouflé / Crochet simple

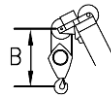

Unterflasche / Hakengehänge
Kraanblok / Kraanhaak

Capacity Capacité Tragfähigkeit Capaciteit	Number of sheaves Nombre de poulies Anzahl der Rollen Aantal schijven	Number of lines Nombre de brins Strangzahl Aantal parten	Weight Poids Gewicht Gewicht	"B"
SWL 200 t / 135 t	10	16 / 10	3.0 t	6.0 m / 4.7 m
SWL 80 t	3	6	1.4 t	5.2 m
SWL 35 t	1	3	0.9 t	4.6 m
SWL 13.5 t	-	1	0.6 t	5.5 m